



CWS INDUSTRIES (MFG) CORP.

## Blades Rating Bulldozers

The following method of calculating the capacity of Bulldozer Blades is representative of the method used by most O.E.M. Heavy Equipment Manufacturers. Similar methods are used for Rating Buckets for Hydraulic Excavators and Buckets for Wheel Loaders.

Use this link for help in understanding Blade Terminology.

The Society of Automotive Engineers publishes standards that define Dozer Capacity. For detailed information contact *SAE* directly on their Web site and ask for:

- SAE Standard J1265 - "Dozer Capacity"

### DOZER CAPACITY

1. **Purpose**-The purpose of this recommended practice is to provide a uniform method for calculating the capacities of dozer blades. It is intended for relative comparisons of dozer blade capacity, and not for predicting capacities or productivities in actual field conditions. Such determinations would need to consider other parameters, such as efficiency of the blade design, tractor power, tractive effort, soil properties, terrain, operator technique, and duty cycle.

#### 2. References

SAE J173, Specification Definitions-Dozers (May, 1970).

SAE J729a, Nomenclature-Dozer (June, 1997).

SAE J1057a, Identification Terminology of Earthmoving Machines (June, 1975).

#### 3. Scope

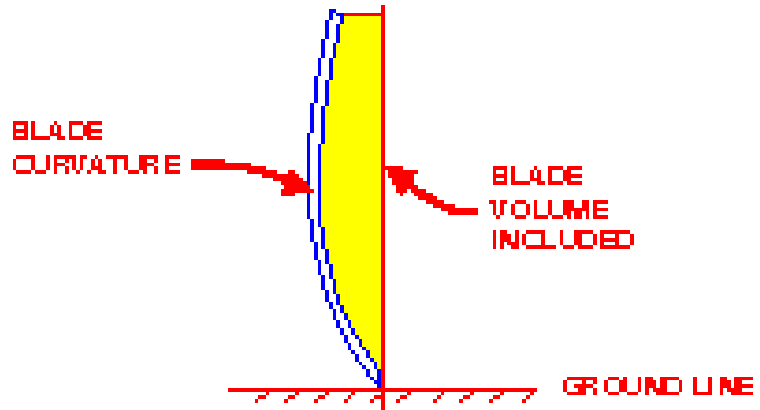

FIG. 1 - BLADE INCLUDED VOLUME

3.1 This recommended practice applies only to straight, angling, semi-U, and U-blade dozers for crawler and wheel tractors. It applies to angling blade dozers only in the straight (not angled) position.

3.2 This recommended practice does not apply to angled blades or other tools used to side cast materials, nor does it apply to any blade with design features such as end plates extended beyond the blade face.

3.3 This recommended practice assumes the blade face to be flat and vertical, and does not consider the blade included volume (Fig.1).

3.4 Although provisions are presented for some deviations, this recommended practice is intended for rectangular blades whose width/height ratios are at least 1.0.

#### 4. Definitions

##### 4.1 Straight Blade Dozers

4.1.1 Blade Projected Area ( $A_m$ , Fig. 2)- Blade area in square meters, exclusive of the end bit extensions, projected on a vertical plane parallel to the width of the blade. The blade is located in the mid-pitch position with the cutting edge at ground line.

4.1.2 Blade Width ( $W$ , Fig.3)-The distance in meters from outside to outside of the blade, exclusive of the end bits.  $W$  corresponds to dimension G of SAE J173.

4.1.3 Effective Blade Height ( $H'$ , Fig. 3)- The vertical height in meters that with  $W$  width, produces a projected area equal to  $A_m$ ; i.e.:  $H' = A_m/W$ .

4.1.4 Effective Blade Contour (Fig. 3)- Simplified representation of the blade face for calculating the blade capacity. It is the vertical plane bounded by  $W$  and  $H'$ .

##### 4.2 Semi-U and U-Blade Dozers

4.2.1 Blade Projected Area ( $A_m$ )-Identical to straight blade (paragraphs 4.1.1, 4.1.2, and 4.1.3).

4.2.2 Blade Width ( $W$ )-Identical to straight

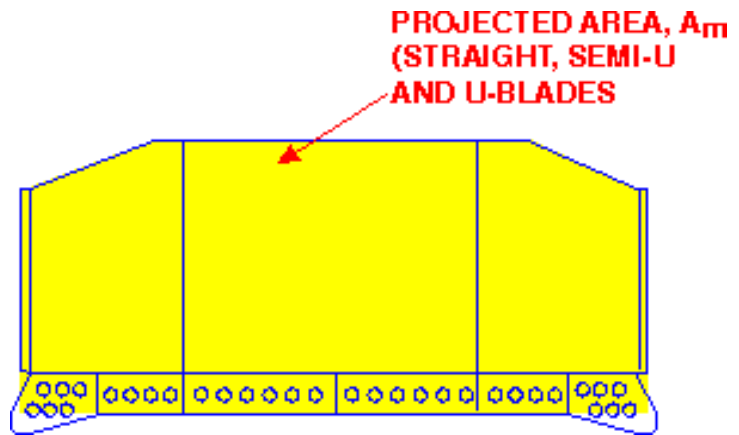

FIG. 2 - BLADE PROJECTED AREA

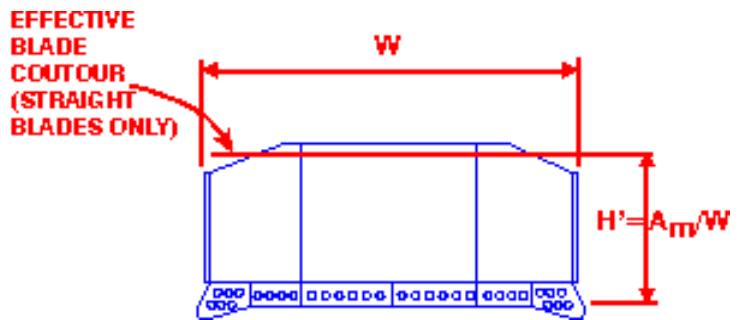

FIG. 3 - STRAIGHT, SEMI-U, U-BLADE DIMENSIONS

blade (paragraphs 4.1.1, 4.1.2, and 4.1.3).

4.2.3 Effective Blade Height ( $H'$ )-Identical to straight blade (paragraphs 4.1.1, 4.1.2, and 4.1.3).

4.2.4 Effective Blade Contour (Fig. 4)-Simplified representation of the blade face for calculating the blade capacity. It is established by intersecting planes extending vertically from the cutting edge at ground line, with the blade in mid-pitch position. The frontal dimensions are  $W$  and  $H'$ .

4.2.5 Wing Angle ( $a$ , Fig. 4)-Wing angle in degrees measured at the cutting edge at ground line with the blade in the mid-pitch position. This angle describes the orientation of the intersecting planes that establish the effective blade contour.

4.2.6 Wing Length ( $Z$ , Fig. 4)-Wing length in meters parallel to the blade width.

### 4.3 Angling Blade Dozers in the Straight Position

4.3.1 Blade Width ( $W$ , Fig. 5)-The minimum blade width in meters.

4.3.2 Effective Blade Height ( $H'$ , Fig. 5)-Vertical height in meters with the blade in the mid-pitch position.  $H'$  corresponds to dimension  $F$  in SAE J173.

4.3.3 Effective Blade Contour (Fig. 5)-Simplified representation of the blade face for calculating the blade capacity. It is the vertical plane bounded by  $W$  and  $H'$ .

### 5. Capacity Formulas (Fig. 6)

5.1 Straight and Angling Blade Capacity:

$$V = V_S = 0.8W(H')^2 (M^3)$$

5.2 Semi-U and U-Blade Capacity:

$$V = V_S + V_U (M^3)$$

$$V_S = 0.8W(H')^2 (M^3)$$

$$V_U = ZH'(W-Z) \tan a (M^3)$$

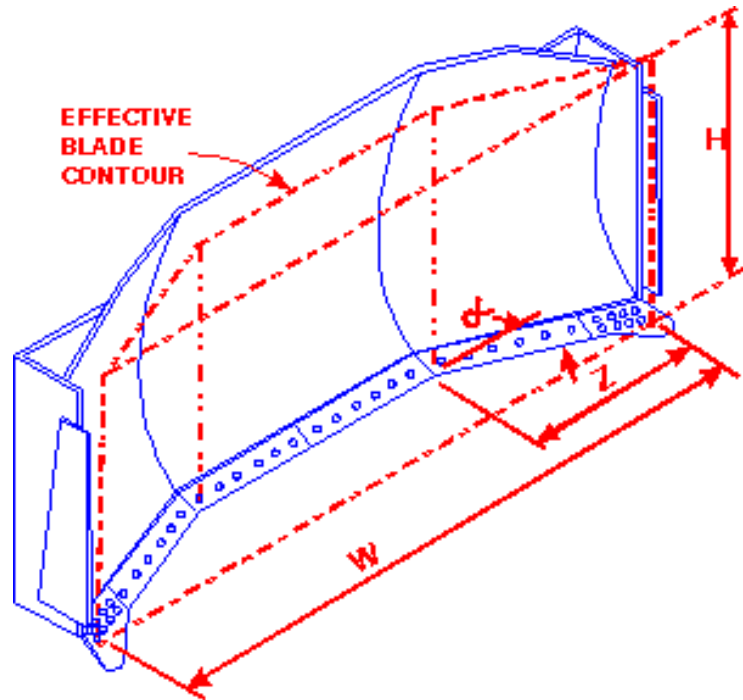

FIG. 4 - EFFECTIVE BLADE CONTOUR - SEMI-U & U-BLADES

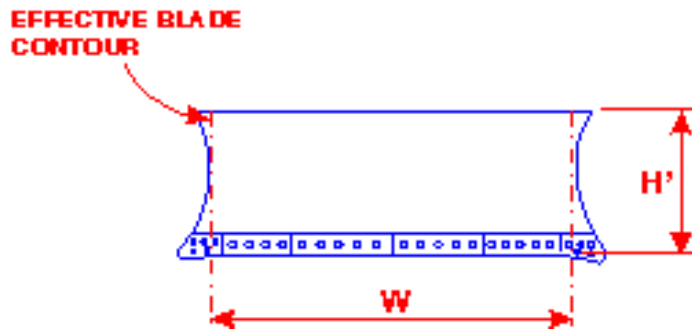

FIG. 5 ANGLING BLADE DIMENSIONS

EFFECTIVE BLADE CONTOUR  
SEMI-U & U-BLADE

STRAIGHT &  
ANGLING  
BLADE

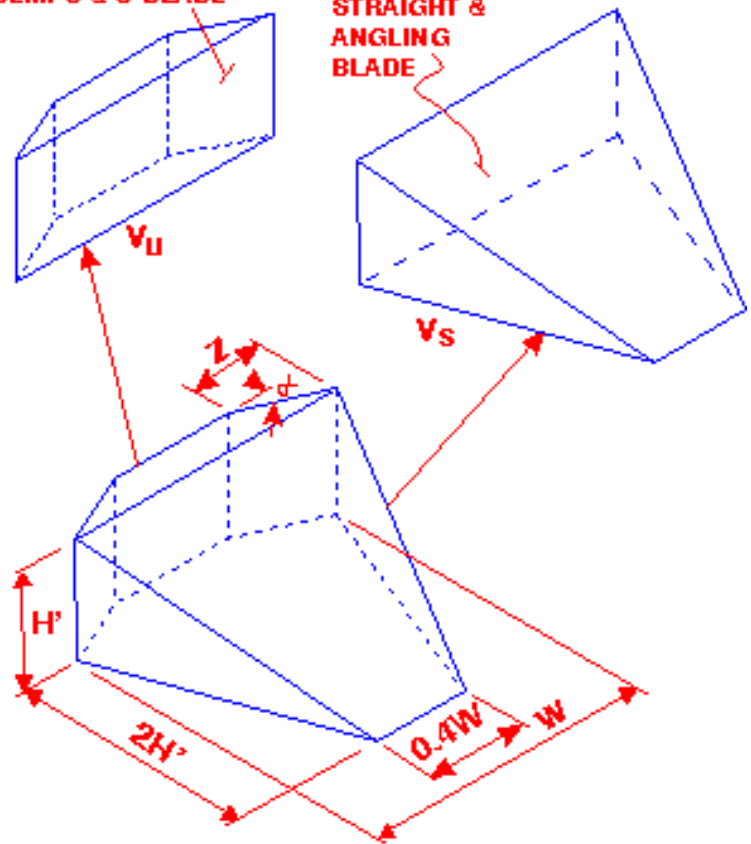

FIG. 6 - BLADE VOLUME