

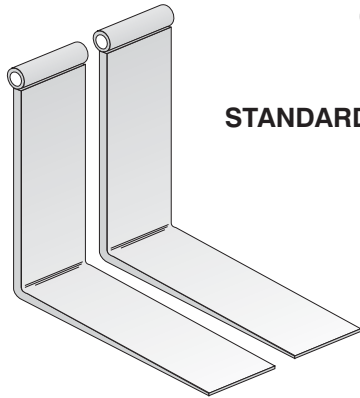

Forks

MADE TO ORDER & REPAIRED

www.imac.ca



STANDARD

**STANDARD TAPERS
FULL OR PARTIAL TAPERS
CHOICE OF FORK TIPS
ALL SIZES & CAPACITIES**

CUSTOM MANUFACTURED FORKS TO YOUR REQUIREMENTS

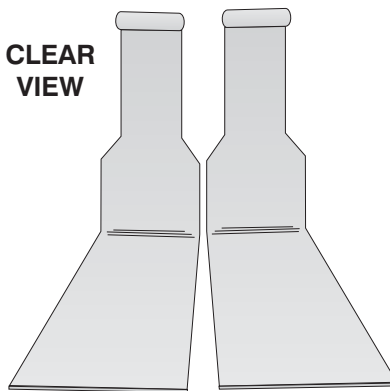

**CLEAR
VIEW**

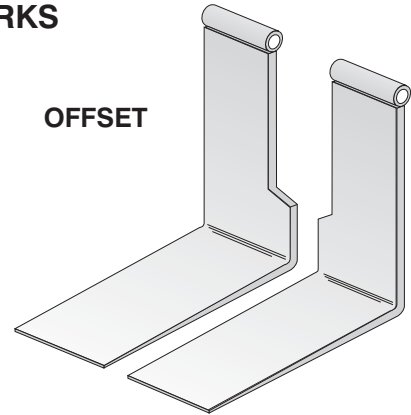

OFFSET

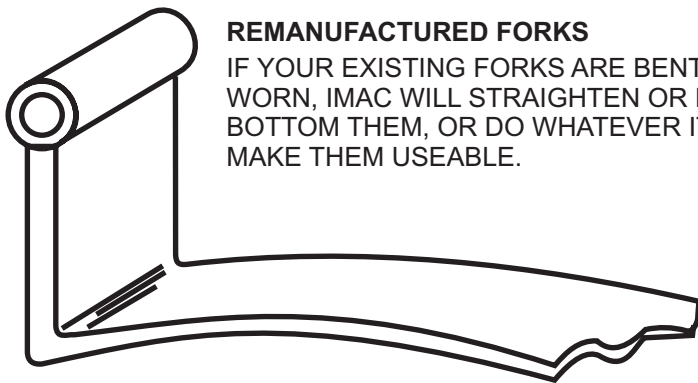

REMANUFACTURED FORKS

IF YOUR EXISTING FORKS ARE BENT OR WORN, IMAC WILL STRAIGHTEN OR RE BOTTOM THEM, OR DO WHATEVER IT TAKES TO MAKE THEM USEABLE.

FORK EXTENSIONS ALL SIZES AND LENGTHS

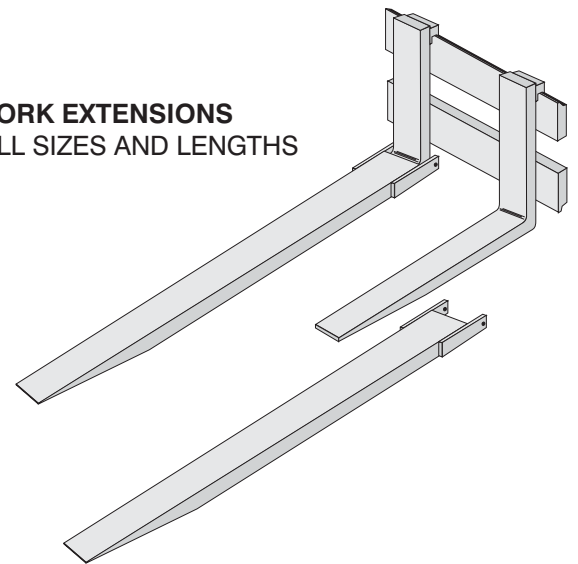

SEND US THE DETAILS OF YOUR REQUIREMENTS
USING THE HANDY ORDER FORM
ON THE REVERSE OF THIS SHEET

COMPANY NAME: _____ TRUCK MAKE: _____
 YOUR NAME: _____ MODEL: _____
 ADDRESS: _____ CAPACITY: _____
 PHONE NUMBER: _____
 FAX NUMBER: _____
 REQUIREMENT: _____ P.O. #: _____

What kind of forks do you need?

SHAFT TYPE FORKS

- A _____ (TO CENTERLINE OF TUBE)
 - B _____ (INSET)
 - C _____ (OFFSET)
 - D _____ (THICKNESS)
 - E _____ (WIDTH)
 - F _____ LENGTH)
 - G _____ (INLINE)
 - H _____
 - 1A _____ (WIDTH)
 - 1B _____ (WIDTH)
 - OD _____ (OUTSIDE DIAMETER)
 - ID _____ (INSIDE DIAMETER)
 - SD _____ (SHAFT DIAMETER)
- CLEARANCE MUST EXIST BETWEEN SHAFT AND TUBE ID

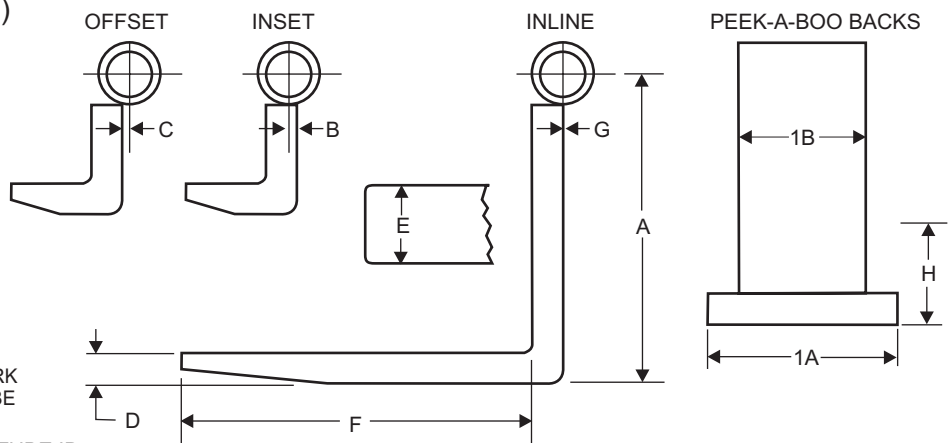

TIPS (Check your choice)



STANDARD TAPER
 A = 18" B = 1/3 Fork Thickness

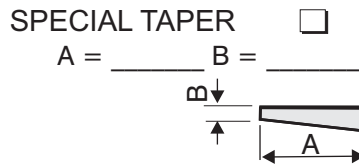

TAPERS (Check your choice)

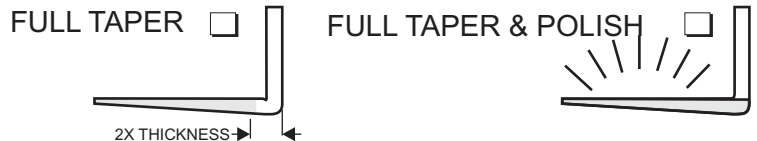

SHAFT TYPE FORKS

NOTE: IF NO SLOT IN TUBE, ONLY DIM. "N" REQUIRED

- J _____ (ANGLE OF SLOT)
- K _____ (DEPTH OF SLOT)
- L _____ (LOCATION OF SLOT)
- M _____ (SLOT WIDTH)
- N _____ (TUBE LENGTH)

